

Thermal Conductivity Gas Sensor

The XEN-5320 is an intelligent gas sensor with a wide application in industry where it is desirable to analyse binary gas mixtures. The sensor is based on the measurement of the thermal conductivity of the ambient gas, using the proven thermal conductivity sensor XEN-3880. Applications include hydrogen and helium gas experimentation, detection of gas dispersion rates in jets and plumes and binary gas composition measurement.



Features

- Long-term stable analysis of gases in binary and quasi-binary mixtures
- Fast response and data update rate
- High sensitivity and resolution
- Long lifetime and low maintenance
- Flow effects compensating design
- Temperature and humidity corrected output
- Allows user zero and gain calibration
- User configurable output calibration curves
- LabView read-out and programming software
- Read-out via USB, CAN or Analog output
- RoHS compliant
- CE and FCC certified

Technical Specification

Preliminary Specifications at 23 °C, 101 kPa, 50 %RH

Mechanical

enclosure	Aluminium
weight	226 g
mounting	Mounting holes, \varnothing 3.2 mm

Environmental

temperature range	-40 to + 85 °C
humidity range	0 to 95 %RH (<i>non-condensing</i>)
pressure range	500-1200 mbar

Electrical

supply Voltage	5 V USB
power consumption	100 mW
maximum cable length	5 m USB

Applications

Monitoring and leak detection of hydrogen, helium, nitrogen and methane gas mixtures in medical, R&D and industrial environments.

Principle of operation

The XEN-5320 determines the gas composition by measuring the temperature elevation of a micromachined heater element. For each binary gas mixture the ratio of temperature increase to heating power is dependent on the mix ratio. For enhanced accuracy, the correction is made for ambient temperature and humidity. The biasing, measurements and correction is done via a Xensor-designed ASIC that utilizes the output from the XEN-TCG3880 thermal conductivity sensor and the temperature and humidity sensor.

Typical Output

The output of the XEN-5320 primarily consists of timestamped information about thermal conductivity transfer and temperature and humidity of the ambient gas. The gas mixture concentration is calculated using the compensated transfer of the thermal conductivity sensor and the user selectable calibration curve for the relevant gas mixture.

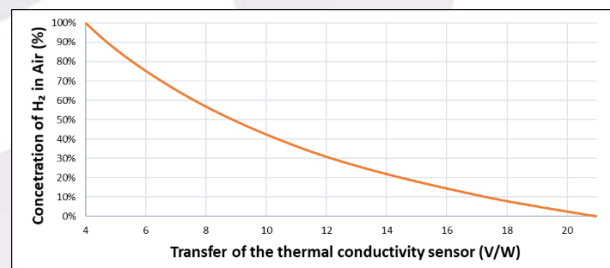

Performance

Preliminary Specifications at 23 °C, 101 kPa, 50 %RH

General

sensitivity for traces of H ₂	-2 %/%
sensitivity for traces of He	-1 %/%
sensitivity for traces of CO ₂	+ 0.3 %/%
inaccuracy H ₂ and He	1%FS
short term drift	< 100 ppm
long term zero drift	0.2 %/yr
range	100 ppm-100%
analog output	0.5 to 2.5 V

Operational speed

system start up time	0.3 s
t ₉₀ response time	< 1 s
t ₁₀ recovery time	< 1 s
t ₆₃ response time RH sensor	8 s
data update rate	3.3 Hz
accelerated Data update rate	40 Hz

LabView software

simultaneous read-out	Up to 25 devices
-----------------------	------------------

Selectivity

The thermal conductivity sensor is non-selective in that it will give an output in the presence of any gas having a thermal conductivity different than air. Measurement of hydrogen or helium in air or nitrogen is particularly attractive, due to the fact that the thermal conductivities of hydrogen and helium are so very different from air and nitrogen.

Calibration

The XEN-5320 offers the possibility to perform a zero and gain calibration. This will position the begin point and the end point of the calibration curve at the right value, minimizing the errors. In addition, the user can capture an own calibration curve for a specific gas mixture and upload it in to the device.

Outline drawing

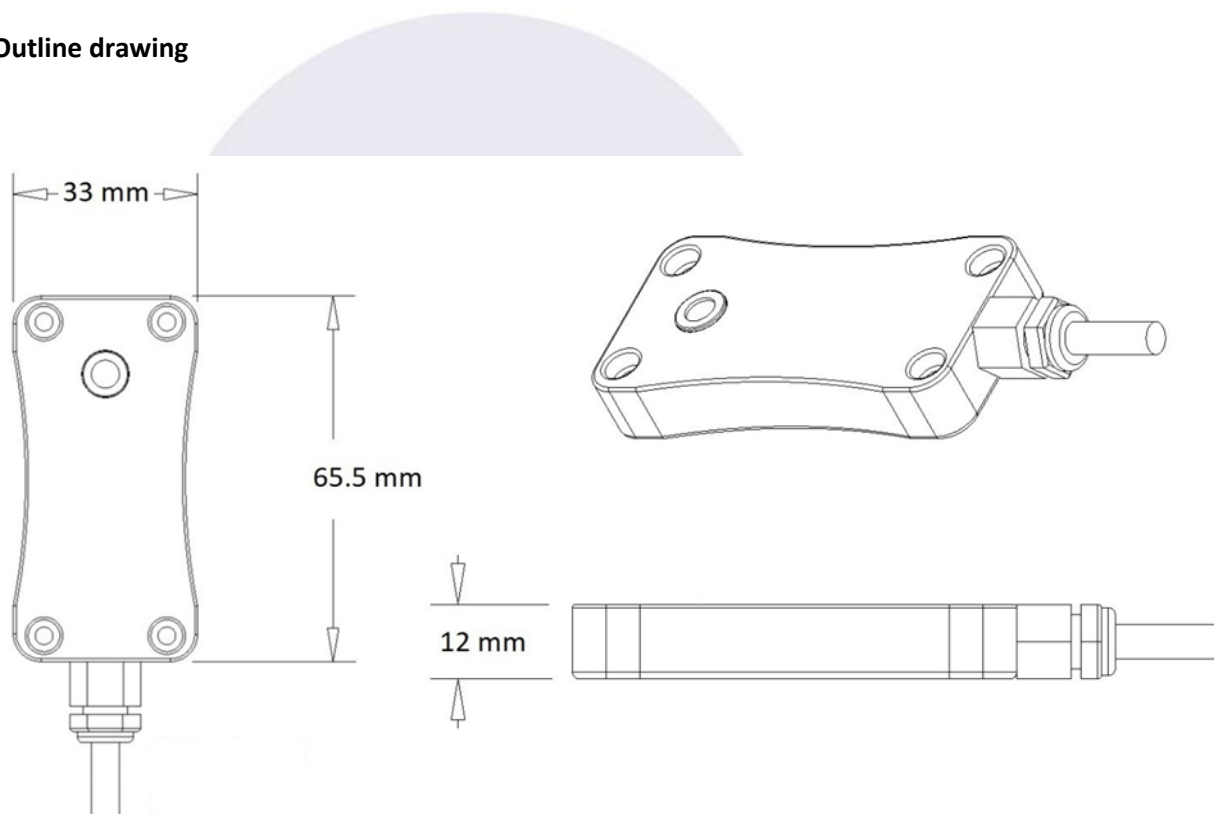

Whilst RS Product Solutions has taken care to ensure the accuracy of the information contained herein it accepts no responsibility for the consequences of any use thereof and also reserves the right to change the specifications of goods without notice. RS Product Solutions accepts no liability beyond set out in its standard conditions of sale in respect of infringement of third party patents arising from the use of RS Product Solutions products in accordance with information contained herein.